

MS-1

扫描引擎

小巧的外形/体积

图示实际尺寸
高: 0.45" (11.5 mm)
宽: 1.26" (32 mm)
长: 0.94" (24 mm)

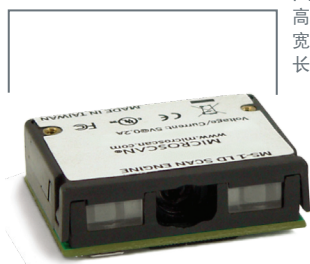

MS-1 是同类产品中最小、最轻的全编码扫描引擎。该产品体形小巧、性能稳定且价格低廉,此外它还提供内置电源管理、进行动态配置的双向串行链路以及高低密度型号。

对于寻求可靠而廉价的嵌入式条形码扫描解决方案的 OEM 设计工程师而言,MS-1 正是理想的扫描引擎。

MS-1: 简介

- 每秒扫描次数: 最多 530 次
- 读取范围: 1.0 至 13" (25 至 330 mm)
- 5 V 低电压供电



ESP® 简易设置程序: 单点软件为所有 Microscan 扫描器提供了迅速简便的设置和配置。

有关详细信息, 请访问 www.microscan.com。

体积小巧, 机身轻盈

MS-1 的规格为 1.26" (32 mm) × 0.95" (24 mm) × 0.44" (11 mm)。引擎的重量不到 0.3 盎司 (8.4 克), 便于安装在自动化设备上或狭小的空间内部。

安装简便

ESP 软件为 MS-1 提供了简便的配置, 包括可选择的触发器和标签设置。

应用实例

- 信息亭
- 收款机终端
- 银行 ATM
- 机器人技术
- 临床仪器

读取性能

MS-1 引擎能轻松读取难以识别的条码, 且非常适合在强反光表面上进行读取。

MS-1: 可读码

线性条码

所有标准



堆栈标签

GS1 Databar 码



PDF417



MICROSCAN®

MS-1 SCAN ENGINE SPECIFICATIONS AND OPTIONS

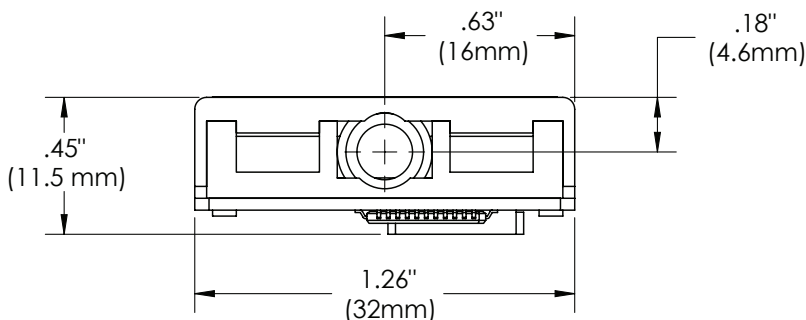
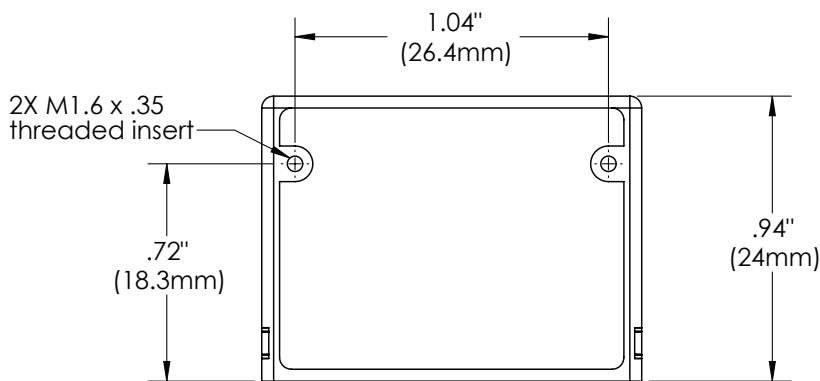

Note: Nominal dimensions shown. Typical tolerances apply.

MECHANICAL

Height: 0.45" (11.5 mm)
 Width: 1.26" (32 mm)
 Length: 0.94" (24 mm)
 Weight: 0.3 oz. (8.4 g)

DESIGN

Flash Memory Sensor:
 CCD linear image sensor
 Optics: 660 nm visible LED
 Bright and sharp scanning line

SCANNING PERFORMANCE

Scan Rate: Up to 530 per second
 Decode Rate: Up to 55 per second
 Min. X Dimension: Down to 3.3 mil
 (0.084 mm) on Code 39
 Depth of Field: 1.0 to 13"
 (25 to 330 mm)
 Barcode Width: Up to 7" (178 mm) on
 20 mil (0.5 mm) resolution code

COMMUNICATION

Interface: USB, RS-232 TTL

CONNECTOR

Type: 12-pin ZIF connector

SYMBOLOGIES

UPC (E&A), EAN, Code 39, Code 128,
 UCC EAN 128, Interleaved, Industrial
 and Standard 2 of 5, Codabar, Code
 93, Plessey, GS1 Databar, PDF417,
 China Postal Code

ENVIRONMENTAL CHARACTERISTICS

Operating Temperature: -20 to 50° C
 (-4 to 122° F)
 Storage Temperature: -30 to 60° C
 (-22 to 140° F)
 Relative Humidity:
 20% to 85% (non-condensing)
 Ambient Light: Works in any lighting
 conditions, from 0 to 70,000 lux
 Shock: 2000G
 Vibration: 50G r.m.s

PIN ASSIGNMENTS

12-Pin ZIF Connector

Pin No.	Decoded Operation	In/Out
1	+5 Power VCC	In
2	TTL_RXD	In
3	Trigger input	In
4	Power enable	In
5	TTL_TXD	Out
6	TTL_RTS	Out
7	Ground	
8	USB_D+	In/Out
9	LED (Engine Status)	Out
10	TTL_CTS	In
11	Buzzer (Decode Indicator)	Out
12	USB_D-	In/Out

CE MARK

Immunity Designed For:
 EN 55024:98 ITE Immunity Standard
 Radiated and Conducted Emissions
 Designed For:
 EN 55022:98 ITE Disturbances Class A

ELECTRICAL

Power: 5V +/- 5%, 300 m/V p-p max ripple,
 120 mA @ 5 VDC (typ.)
 Start Up Time: 175 ms



HIGH DENSITY FIELDS OF VIEW

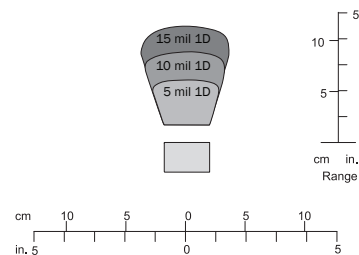

LOW DENSITY FIELDS OF VIEW

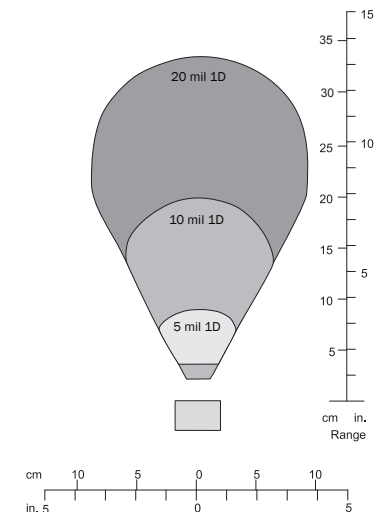

READ RANGES

Narrow-Bar	Read Range	Scan Width
HIGH DENSITY		
.005" (.127 mm)	0.6 to 2.1" (15 to 53 mm)	2.2" (56 mm) @ 1.6" (41 mm)
.010" (.254 mm)	0.6 to 4.1" (15 to 104 mm)	4.3" (109 mm) @ 3.2" (81 mm)
.015" (.38 mm)	0.6 to 5.1" (15 to 130 mm)	5.0" (127 mm) @ 4.5" (114 mm)
LOW DENSITY		
.005" (.127 mm)	1.8 to 3.6" (46 to 91 mm)	2.2" (56 mm) @ 3" (76 mm)
.010" (.254 mm)	1.8 to 7.0" (46 to 178 mm)	3.9" (99 mm) @ 6" (152 mm)
.020" (.508 mm)	1.8 to 12.6" (46 to 320 mm)	6.7" (170 mm) @ 11" (279 mm)

SAFETY CERTIFICATIONS DESIGNED FOR
 FCC, CE

ROHS/WEEE COMPLIANT

ISO CERTIFICATION

Certified ISO 9001:2008 Quality Management System

©2010 Microscan Systems, Inc. SP015G-C 09/10

Read Range and other performance data is determined using high quality Grade A symbols per ISO/IEC 15415 and ISO/IEC 15416 in a 25° C environment. For application-specific Read Range results, testing should be performed with symbols used in the actual application. Microscan Applications Engineering is available to assist with evaluations. Results may vary depending on symbol quality. Warranty- One year limited warranty on parts and labor. Free extended three year warranty available with online product registration.

MICROSCAN®

Microscan Systems, Inc. 公司
 电话: +1 425 226 5700 / 800 251 7711
 传真: +1 425 226 8250
 Microscan 亚太有限公司
 电话: +65 6846 1214
 传真: +65 6846 4641
 Microscan

产品信息:

info@microscan.com
 自动识别支持:
 helpdesk@microscan.com
 视觉支持:
 visionsupport@microscan.com
 NERLITE 支持:
 nerlitesupport@microscan.com